

FOR SOFT OR UNSTABLE SUBGRADE SEE DETAIL BELOW.

TYPICAL TRENCH

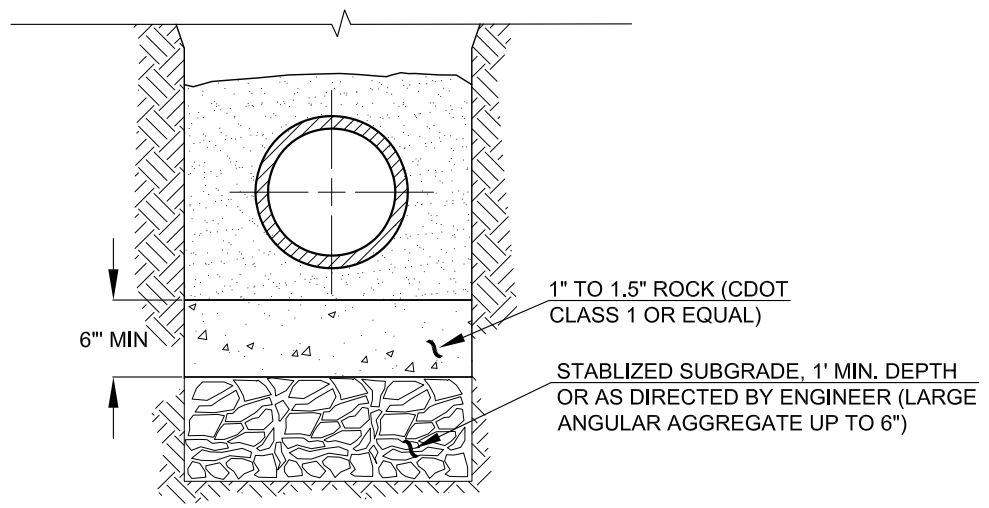

UNSTABLE SUBGRADE

NOTES:

1. NEW STREET SURFACE SHALL COMPLY WITH LOCAL JURISDICTION.
2. TRENCH WALLS TO BE SUPPORTED AS REQUIRED BY OSHA.
3. WHEN IT IS NECESSARY TO LOWER OR RAISE WATER LINES AT STORM DRAINS AND OTHER UTILITY CROSSINGS, A MINIMUM CLEARANCE OF 1.50 FEET SHALL BE MAINTAINED BETWEEN THE OUTSIDES OF THE PIPES

REV. DATE:	10/2012	TRENCH SECTION
SCALE:	N.T.S.	
 NORTH TABLE MOUNTAIN WATER AND SANITATION DISTRICT		DWG. NO.
14806 WEST 52ND AVENUE GOLDEN, COLORADO 80403-1228		W1